

Series JBB/4

SET-1

रोल नं.

Roll No.

--	--	--	--	--	--	--	--

कोड नं. **31/4/1**  
Code No.

परीक्षार्थी कोड को उत्तर-पुस्तिका के मुख-पृष्ठ पर अवश्य लिखें।

Candidates must write the Code on the title page of the answer-book.

नोट	NOTE
(I) कृपया जाँच कर लें कि इस प्रश्न-पत्र में मुद्रित पृष्ठ <b>23</b> हैं।	(I) Please check that this question paper contains <b>23</b> printed pages.
(II) प्रश्न-पत्र में दाहिने हाथ की ओर दिए गए कोड नम्बर को छात्र उत्तर-पुस्तिका के मुख-पृष्ठ पर लिखें।	(II) Code number given on the right hand side of the question paper should be written on the title page of the answer-book by the candidate.
(III) कृपया जाँच कर लें कि इस प्रश्न-पत्र में <b>30</b> प्रश्न हैं।	(III) Please check that this question paper contains <b>30</b> questions.
(IV) कृपया प्रश्न का उत्तर लिखना शुरू करने से पहले, उत्तर-पुस्तिका में प्रश्न का क्रमांक अवश्य लिखें।	(IV) Please write down the serial number of the question in the answer-book before attempting it.
(V) इस प्रश्न-पत्र को पढ़ने के लिए 15 मिनट का समय दिया गया है। प्रश्न-पत्र का वितरण पूर्वाह्न में 10.15 बजे किया जाएगा। 10.15 बजे से 10.30 बजे तक छात्र केवल प्रश्न-पत्र को पढ़ेंगे और इस अवधि के दौरान वे उत्तर-पुस्तिका पर कोई उत्तर नहीं लिखेंगे।	(V) 15 minute time has been allotted to read this question paper. The question paper will be distributed at 10.15 a.m. From 10.15 a.m. to 10.30 a.m., the students will read the question paper only and will not write any answer on the answer-book during this period.

## विज्ञान

### SCIENCE

निर्धारित समय : 3 घण्टे

अधिकतम अंक : 80

Time allowed : 3 hours

Maximum Marks : 80

### सामान्य निर्देश:

निम्नलिखित निर्देशों को बहुत सावधानी से पढ़िए और उनका सख्ती से पालन कीजिए :

- यह प्रश्न-पत्र तीन खण्डों में विभाजित किया गया है — क, ख और ग । इस प्रश्न-पत्र में प्रश्नों की संख्या 30 है । सभी प्रश्न अनिवार्य हैं ।
- खण्ड क के सभी प्रश्न/उनके भाग, प्रश्न संख्या 1 से 14 तक एक-एक अंक के हैं । इन प्रश्नों में बहुविकल्पी प्रश्न, अति लघु-उत्तरीय प्रश्न तथा अभिकथन-कारण प्रकार के प्रश्नों को सम्मिलित किया गया है । इन प्रश्नों के उत्तर एक शब्द अथवा एक वाक्य में दिए जाने चाहिए ।
- खण्ड ख में प्रश्न संख्या 15 से 24 तक लघु-उत्तरीय प्रकार के प्रश्न हैं, प्रत्येक प्रश्न 3 अंक का है । इन प्रश्नों का उत्तर 50 से 60 शब्दों से अधिक नहीं होना चाहिए ।
- खण्ड ग में प्रश्न संख्या 25 से 30 तक दीर्घ-उत्तरीय प्रकार के प्रश्न हैं, प्रत्येक प्रश्न 5 अंक का है । इन प्रश्नों का उत्तर 80 से 90 शब्दों से अधिक नहीं होना चाहिए ।
- उत्तर संक्षिप्त तथा बिंदुवार होने चाहिए और साथ ही उपर्युक्त शब्द सीमा का यथासंभव पालन किया जाना चाहिए ।
- प्रश्न-पत्र में समग्र पर कोई विकल्प नहीं है । तथापि प्रत्येक खण्ड में कुछ प्रश्नों में आंतरिक विकल्प दिए गए हैं । ऐसे प्रश्नों में से केवल एक ही विकल्प का उत्तर लिखिए ।
- इसके अतिरिक्त, आवश्यकतानुसार, प्रत्येक खण्ड और प्रश्न के साथ यथोचित निर्देश दिए गए हैं ।

### खण्ड क

- नाइट्रोजन परमाणु ( ${}^{14}_7\text{N}$ ) में उपस्थित संयोजी इलेक्ट्रॉनों की संख्या लिखिए । 1
- प्रेरित विद्युत् धारा की परिभाषा लिखिए । 1
- निम्नलिखित अनुच्छेद और पढ़ी गयीं संबंधित संकल्पनाओं की व्याख्या के आधार पर प्रश्न संख्या 3(a) से 3(d) के उत्तर दीजिए :

सन् 1800 के लगभग तक केवल 30 तत्त्व ही ज्ञात थे । 1817 में डॉबेराइनर और 1866 में न्यूलैंड्स ने तब तक ज्ञात तत्त्वों को व्यवस्थित करने के लिए प्रयास किए और कुछ नियम बनाए जिन्हें वैज्ञानिकों ने अस्वीकार कर दिया । उन प्रस्तावित नियमों के अस्वीकार किए जाने के पश्चात् भी कई वैज्ञानिकों ने ऐसे प्रतिरूपों की खोज जारी रखी जिससे तत्त्वों के गुणधर्मों का उनके परमाणु द्रव्यमानों के साथ संबंध स्थापित हो सके ।

**General Instructions :**

Read the following instructions very carefully and strictly follow them.

- (i) This question paper comprises **three** Sections — **A, B** and **C**. There are **30** questions in the question paper. **All** questions are compulsory.
- (ii) **Section A** – Questions no. **1** to **14** — all questions or part thereof are of **one** mark each. These questions comprise Multiple Choice Questions (MCQ), Very Short Answer (VSA) and Assertion–Reason type questions. Answer to these questions should be given in **one word** or **one sentence**.
- (iii) **Section B** – Questions no. **15** to **24** are short answer type questions, carrying **3** marks each. Answer to these questions should not exceed **50** to **60** words.
- (iv) **Section C** – Questions no. **25** to **30** are long answer type questions, carrying **5** marks each. Answer to these questions should not exceed **80** to **90** words.
- (v) Answers should be brief and to the point. Also the above mentioned word limit be adhered to as far as possible.
- (vi) There is no overall choice in the question paper. However, an internal choice has been provided in some questions in each section. **Only one of the choices** in such questions have to be attempted.
- (vii) In addition to this, separate instructions are given with each section and question, wherever necessary.

**SECTION A**

1. Write the number of valence electrons present in a nitrogen atom ( ${}^{14}_7\text{N}$ ). 1  
**Periodic Classification of Elements**
2. Define the term induced electric current. 1  
**Magnetic Effect of Current**
3. Answer question numbers 3(a) – 3(d) on the basis of your understanding of the following paragraph and the related studied concepts :

Around the year 1800, only 30 elements were known. Dobereiner in 1817 and Newlands in 1866 tried to arrange the then known elements and framed laws which were rejected by the scientists. Even after the rejection of the proposed laws, many scientists continued to search for a pattern that correlated the properties of elements with their atomic masses.

**Periodic Classification of Elements**



तत्त्वों के वर्गीकरण का मुख्य श्रेय मेन्डेलीफ को जाता है, जिन्होंने तत्त्वों की आवर्त सारणी के प्रारंभिक विकास में सर्वाधिक महत्वपूर्ण योगदान दिया। उन्होंने तत्त्वों को उनके मूल गुणधर्म, परमाणु द्रव्यमान तथा रासायनिक गुणधर्मों में समानता के आधार पर व्यवस्थित किया। उनके हाइड्राइडों और ऑक्साइडों के सूत्रों को तत्त्वों के वर्गीकरण का मूल मापदण्ड माना गया।

परन्तु मेन्डेलीफ के वर्गीकरण में भी कुछ कमियाँ थीं, क्योंकि इसमें समस्थानिकों को कोई स्थान नहीं दिया गया था। उन्होंने आवर्त सारणी में कुछ रिक्त स्थान भी छोड़ दिए थे।

- 3(a) मेन्डेलीफ का आवर्त नियम लिखिए। 1
- 3(b) मेन्डेलीफ ने आवर्त सारणी में कुछ रिक्त स्थान क्यों छोड़ दिए थे ? 1
- 3(c) यदि किसी समूह में किसी तत्व को 'R' अक्षर से निरूपित किया जाता है, तो कार्बन के हाइड्राइड और ऑक्साइड को क्रमशः किस प्रकार निरूपित किया जाएगा ? 1
- (i)  $RH_4, RO$
- (ii)  $RH_4, RO_2$
- (iii)  $RH_2, RO_2$
- (iv)  $RH_2, RO$
- 3(d) समस्थानिक 1
- (i) किसी तत्व के वह परमाणु हैं जिनके रासायनिक गुणधर्म समान परन्तु परमाणु द्रव्यमान भिन्न होते हैं।
- (ii) भिन्न-भिन्न तत्वों के वह परमाणु हैं जिनके रासायनिक गुणधर्म समान परन्तु परमाणु द्रव्यमान भिन्न होते हैं।
- (iii) किसी तत्व के वह परमाणु हैं जिनके रासायनिक गुणधर्म भिन्न परन्तु परमाणु द्रव्यमान समान होते हैं।
- (iv) भिन्न-भिन्न तत्वों के वह परमाणु हैं जिनके रासायनिक गुणधर्म भिन्न परन्तु परमाणु द्रव्यमान समान होते हैं।





The main credit for classifying elements goes to Mendeleev for his most important contribution to the early development of a Periodic table of elements wherein he arranged the elements on the basis of their fundamental property, the atomic mass and also on the similarity of chemical properties. The formulae of their hydrides and oxides were treated as basic criteria for the classification of the elements.

However, Mendeleev's classification also had some limitations as it could not assign the position to isotopes. He also left some gaps in the periodic table.

- 3(a) State Mendeleev's Periodic Law. 1
- 3(b) Why did Mendeleev leave some gaps in the Periodic table? 1
- 3(c) If the letter 'R' was used to represent any of the elements in the group, then the hydride and oxide of carbon would respectively be represented as 1
- Periodic Classification of Elements
- (i)  $RH_4$ ,  $RO$
- (ii)  $RH_4$ ,  $RO_2$
- (iii)  $RH_2$ ,  $RO_2$
- (iv)  $RH_2$ ,  $RO$
- 3(d) Isotopes are 1
- (i) Atoms of an element with similar chemical properties but different atomic masses.
- (ii) Atoms of different elements with similar chemical properties but different atomic masses.
- (iii) Atoms of an element with different chemical properties but same atomic masses.
- (iv) Atoms of different elements with different chemical properties but same atomic masses.

Periodic Classification of Elements

4. निम्नलिखित अनुच्छेद और पढ़ी गयीं संबंधित संकल्पनाओं की व्याख्या के आधार पर प्रश्न संख्या 4(a) से 4(d) के उत्तर दीजिए :

भारत आज संसाधनों के अत्यधिक दोहन, जल और मृदा के संदूषण तथा कचरे को संसाधित करने की विधियों की कमी की समस्या का सामना कर रहा है। अब समय आ गया है कि संसार “एकल-उपयोग प्लास्टिक” को विदा कहे। इसके पर्यावरण-हितैषी विकल्पों, अपशिष्ट प्लास्टिक का प्रभावी एकत्रीकरण और उसका निपटारा करने की विधियाँ विकसित करने के लिए प्रयास किए जाने चाहिए।

इन्दौर ने मात्र 3 वर्ष में जैव-खनन और जैव-उपचार्य की प्रक्रियाओं द्वारा 15 लाख मीट्रिक टन कचरे को संसाधित किया है। जैव-उपचार्य में किसी लैण्डफिल में जीवाणुओं को डालकर कचरे को प्राकृतिक रूप से ‘अपघटित’ किया जाता है तथा जैव-खनन में ट्रूमल मशीनों द्वारा कचरे को छानकर ‘मृदा’ को कचरे से पृथक् किया जाता है। इस शहर ने लगभग 10 करोड़ रुपये खर्च करके 15 लाख मीट्रिक टन कचरे का निपटारा करने में सफलता पाई। ऐसा ही एक सफल प्रयोग अहमदाबाद में भी किया गया।

- 4(a) अपने विद्यालय में अपशिष्ट प्लास्टिक को एकत्र करने की दो प्रभावी विधियों का उल्लेख कीजिए। 1
- 4(b) “एकल-उपयोग प्लास्टिक” के दैनिक जीवन में कोई दो उपयोग लिखिए। 1
- 4(c) यदि प्लास्टिक का उपयोग रोक दिया जाए, तो इसके स्थान पर कोई पर्यावरण-हितैषी विकल्प कैसे प्रदान किया जा सकता है? 1
- 4(d) क्या आप ऐसा सोचते हैं कि लैण्डफिल स्थल में जीवाणु उसी प्रकार कार्य करेंगे जैसा वे प्रयोगशाला में करते हैं? अपने उत्तर की पुष्टि कीजिए। 1



4. Answer question numbers 4(a) – 4(d) on the basis of your understanding of the following paragraph and the related studied concepts :

India today is facing the problem of overuse of resources, contamination of water and soil and lack of methods of processing the waste. The time has come for the world to say goodbye to “single-use plastics”. Steps must be undertaken to develop environment-friendly substitutes, effective plastic waste collection and methods of its disposal.

Indore treated 15 lakh metric tonnes of waste in just 3 years, through biomining and bioremediation techniques. Bioremediation involves introducing microbes into a landfill to naturally ‘break’ it down and biomining involves using trommel machines to sift through the waste to separate the ‘soil’ and the waste component. The city managed to chip away 15 lakh metric tonnes of waste at a cost of around ₹ 10 crore. A similar experiment was successfully carried out in Ahmedabad also.

### Management of Natural Resources

- 4(a) State two methods of effective plastic waste collection in your school. 1
- 4(b) Name any two uses of “single-use plastic” in daily life. 1
- 4(c) If we discontinue the use of plastic, how can an environment-friendly substitute be provided ? 1
- 4(d) Do you think microbes will work similarly in landfill sites as they work in the laboratory ? Justify your answer. 1

5. मानव परिसंचरण तंत्र के विषय में निम्नलिखित में से कौन-सा कथन सही है ? 1
- (A) रुधिर केवल ऑक्सीजन का वहन करता है तथा कार्बन डाइऑक्साइड का वहन नहीं करता ।
- (B) मानव हृदय में पाँच कोष्ठ होते हैं ।
- (C) वाल्व रुधिर के पश्च प्रवाह पर रोक को सुनिश्चित करते हैं ।
- (D) हृदय में ऑक्सीजन-बहुल और ऑक्सीजन-न्यून दोनों रुधिर मिश्रित होते हैं ।
6. अवायवीय प्रक्रिया 1
- (A) किण्वन के समय यीस्ट में होती है ।
- (B) ऑक्सीजन की उपस्थिति में होती है ।
- (C) मानवों की पेशियों में केवल ऊर्जा उत्पन्न करती है ।
- (D) में एथेनॉल, ऑक्सीजन और ऊर्जा उत्पन्न होती है ।
- अथवा**
- भोजन का अधिकांश पाचन और अवशोषण कहाँ होता है ? 1
- (A) क्षुद्रांत्र में
- (B) यकृत में
- (C) आमाशय में
- (D) बृहद्रांत्र में
7. निषेचन वह प्रक्रिया है जिसमें 1
- (A) नर युग्मक का मादा युग्मक की ओर स्थानान्तरण होता है ।
- (B) नर और मादा युग्मक के केन्द्रकों का संलयन होता है ।
- (C) नर और मादा जननांगों का आसंजन (चिपकाव) होता है ।
- (D) किसी जननांग द्वारा युग्मक बनते हैं ।





5. Which one of the following statements is correct about the human circulatory system ? Life Processes 1
- (A) Blood transports only oxygen and not carbon dioxide.
- (B) Human heart has five chambers.
- (C) Valves ensure that the blood does not flow backwards.
- (D) Both oxygen-rich and oxygen-deficient blood gets mixed in the heart.
6. Anaerobic process Life Processes 1
- (A) takes place in yeast during fermentation.
- (B) takes place in the presence of oxygen.
- (C) produces only energy in the muscles of human beings.
- (D) produces ethanol, oxygen and energy.
- OR**
- Most of the digestion and absorption of the food takes place in the Life Processes 1
- (A) small intestine.
- (B) liver.
- (C) stomach.
- (D) large intestine.
7. Fertilisation is the process of How Do Organisms Reproduce 1
- (A) transfer of male gamete to female gamete.
- (B) fusion of nuclei of male and female gamete.
- (C) adhesion of male and female reproductive organs.
- (D) the formation of gametes by a reproductive organ.

8. यदि किसी व्यक्ति के पास पाँच प्रतिरोधक हैं जिनमें प्रत्येक का प्रतिरोध  $\frac{1}{5} \Omega$  है, तो वह इन्हें संयोजित करके कितना अधिकतम प्रतिरोध प्राप्त कर सकता है ? 1

- (A)  $1 \Omega$
- (B)  $5 \Omega$
- (C)  $10 \Omega$
- (D)  $25 \Omega$

अथवा

किसी प्रतिरोधक का प्रतिरोध उसके प्रारम्भिक मान का आधा कर दिया गया है। ऐसा करने में, यदि परिपथ के अन्य प्राचलों को परिवर्तित न किया जाए, तो इस प्रतिरोधक में तापन प्रभाव हो जाएगा 1

- (A) दुगुना
- (B) आधा
- (C) एक-चौथाई
- (D) चार गुना

9. फ्लेमिंग का दक्षिण-हस्त नियम बताता है 1

- (A) प्रेरित धारा का परिमाण।
- (B) चुम्बकीय क्षेत्र का परिमाण।
- (C) प्रेरित धारा की दिशा।
- (D) प्रेरित धारा की दिशा और परिमाण, दोनों।



8. If a person has five resistors each of value  $\frac{1}{5} \Omega$ , then the maximum resistance he can obtain by connecting them is 1

- (A)  $1 \Omega$
- (B)  $5 \Omega$
- (C)  $10 \Omega$
- (D)  $25 \Omega$

Electricity

**OR**

The resistance of a resistor is reduced to half of its initial value. In doing so, if other parameters of the circuit remain unchanged, the heating effects in the resistor will become 1

- (A) two times.
- (B) half.
- (C) one-fourth.
- (D) four times.

Electricity

9. Fleming's Right-hand rule gives

Magnetic Effect of Current

1

- (A) magnitude of the induced current.
- (B) magnitude of the magnetic field.
- (C) direction of the induced current.
- (D) both, direction and magnitude of the induced current.

10. किसी नाभिकीय रिएक्टर में नाभिकीय ऊर्जा उत्पन्न करने के बारे में निम्नलिखित में से कौन-सा कथन सत्य **नहीं** है ?

1

- (A) इसमें ऊर्जा नाभिकीय विखण्डन की प्रक्रिया द्वारा प्राप्त होती है ।
- (B) इसमें यूरेनियम के नाभिक पर उच्च ऊर्जा वाले न्यूट्रॉनों की बमबारी की जाती है ।
- (C) इस प्रक्रिया में शृंखला अभिक्रिया होती है ।
- (D) इस प्रक्रिया में नियंत्रित दर पर विशाल मात्रा में ऊर्जा मुक्त होती है ।

**अथवा**

पृथ्वी के पृष्ठ पर ऊर्जा का सबसे बड़ा स्रोत है

1

- (A) जैवमात्रा (बायोमास)
- (B) सौर विकिरण
- (C) ज्वार-भाटा
- (D) पवन

11. आहार जाल बनता है

1

- (A) जीवों और पर्यावरण के बीच संबंध द्वारा
- (B) पादपों और जन्तुओं के बीच संबंध द्वारा
- (C) किसी पारितंत्र में विभिन्न आहार शृंखलाओं के जोड़ से
- (D) जन्तुओं और पर्यावरण के बीच संबंध द्वारा

12. निम्नलिखित में से **असत्य** कथन चुनिए :

1

- (A) ऑक्सीजन के तीन परमाणुओं से ओज़ोन का एक अणु बनता है ।
- (B) ओज़ोन पराबैंगनी विकिरणों से पृथ्वी के पृष्ठ की सुरक्षा करती है ।
- (C) ओज़ोन अत्यन्त विषैली होती है ।
- (D) ओज़ोन पराबैंगनी विकिरणों द्वारा अपघटित (वियोजित) हो जाती है ।





10. Which one of the following statements is **not** true about nuclear energy generation in a nuclear reactor ? 1

- (A) Energy is obtained by a process called nuclear fission.
- (B) The nucleus of Uranium is bombarded with high energy neutrons.
- (C) A chain reaction is set in the process. Sources of Energy
- (D) In this process a tremendous amount of energy is released at a controlled rate.

OR

The biggest source of energy on Earth's surface is 1

- (A) Biomass Sources of Energy
- (B) Solar radiations
- (C) Tides
- (D) Winds

11. Food web is constituted by Our Environment 1

- (A) relationship between the organisms and the environment.
- (B) relationship between plants and animals.
- (C) various interlinked food chains in an ecosystem.
- (D) relationship between animals and environment.

12. Choose the **incorrect** statement from the following : Our Environment 1

- (A) Ozone is a molecule formed by three atoms of oxygen.
- (B) Ozone shields the surface of the Earth from ultraviolet radiations.
- (C) Ozone is deadly poisonous.
- (D) Ozone gets decomposed by UV radiations.

प्रश्न संख्या 13 और 14 के लिए, दो कथन दिए गए हैं जिनमें एक को अभिकथन (A) तथा दूसरे को कारण (R) द्वारा अंकित किया गया है। इन प्रश्नों के सही उत्तर नीचे दिए गए कोडों (a), (b), (c) और (d) में से चुनकर दीजिए।

- (a) (A) और (R) दोनों सही हैं और (R), अभिकथन (A) की सही व्याख्या करता है।  
 (b) (A) और (R) दोनों सही हैं, परन्तु (R), अभिकथन (A) की सही व्याख्या नहीं करता है।  
 (c) (A) सही है, परन्तु (R) ग़लत है।  
 (d) (A) ग़लत है, परन्तु (R) सही है।

13. अभिकथन (A) : निम्नलिखित संतुलित रासायनिक समीकरण आयरन पर भाप की क्रिया के लिए है :



कारण (R) : किसी रासायनिक समीकरण पर द्रव्यमान के संरक्षण का नियम लागू होता है।

1

14. अभिकथन (A) : मानवों में किसी शिशु का लिंग उसके पिता द्वारा वंशानुगत गुणसूत्र के प्रकार द्वारा निर्धारित होता है।

कारण (R) : वह शिशु जो अपने पिता से 'X' गुणसूत्र वंशानुगत करता है लड़की (XX) होती है जबकि वह शिशु जो अपने पिता से 'Y' गुणसूत्र वंशानुगत करता है लड़का (XY) होता है।

1

### खण्ड ख

15. कोई परखनली, जिसमें पोटैशियम आयोडाइड का विलयन भरा है, में लैड नाइट्रेट विलयन मिलाया गया है।

- (a) अवक्षेपित यौगिक का नाम और रंग लिखिए।  
 (b) होने वाली अभिक्रिया का संतुलित रासायनिक समीकरण लिखिए।  
 (c) इस अभिक्रिया के प्रकार का नाम लिखिए और अपने उत्तर की पुष्टि कीजिए।

3

### अथवा

क्या होता है जब वसा तथा तैलीय खाद्य सामग्री लम्बे समय तक रखी रह जाती है ? प्रेक्षण योग्य दो परिवर्तनों की सूची बनाइए और इस परिघटना से बचाव के तीन उपाय सुझाइए।

3



**For question numbers 13 and 14, two statements are given — one labelled as Assertion (A) and the other labelled as Reason (R). Select the correct answer to these questions from the codes (a), (b), (c) and (d) as given below :**

- (a) Both (A) and (R) are true and (R) is the correct explanation of the assertion (A).
- (b) Both (A) and (R) are true, but (R) is **not** the correct explanation of the assertion (A).
- (c) (A) is true, but (R) is false.
- (d) (A) is false, but (R) is true.

**13.** *Assertion (A)* : Following is a balanced chemical equation for the action of steam on iron :

Chemical Reactions and Equation



*Reason (R)* : The law of conservation of mass holds good for a chemical equation. 1

**14.** *Assertion (A)* : The sex of a child in human beings will be determined by the type of chromosome he/she inherits from the father.

*Reason (R)* : A child who inherits 'X' chromosome from his father would be a girl (XX), while a child who inherits a 'Y' chromosome from the father would be a boy (XY). 1

### SECTION B

**15.** Lead nitrate solution is added to a test tube containing potassium iodide solution. 3

- (a) Write the name and colour of the compound precipitated.
- (b) Write the balanced chemical equation for the reaction involved.
- (c) Name the type of this reaction justifying your answer. 3

**OR**

What happens when food materials containing fats and oils are left for a long time ? List two observable changes and suggest three ways by which this phenomenon can be prevented. 3

16. यशदलेपन तथा मिश्रात्वन की प्रक्रियाओं के बीच तीन विभेदनकारी लक्षणों की सूची बनाइए । 3

अथवा

तालिका के रूप में निम्नलिखित धातुओं की ठंडे और गर्म जल के साथ अभिक्रियाशीलताओं की तुलना कीजिए :

- (a) सोडियम  
(b) कैल्सियम  
(c) मैग्नीशियम

3

17. कार्बन, जो कि समूह 14 का सदस्य है, अत्यधिक संख्या में कार्बन यौगिकों का निर्माण करता है जिनकी अनुमानित संख्या लगभग 30 लाख है । इसी गुणधर्म को इसी समूह के अन्य तत्त्व प्रदर्शित क्यों नहीं करते हैं ? व्याख्या कीजिए ।

3

18. कोई चीता, अपने शिकार को देखकर, उसकी ओर अत्यधिक तीव्र गति से दौड़ता है । उसकी पेशियों को किस प्रकार गति मिलती है ? इस परिघटना के समय पेशियों के कोशिकीय अवयवों के रसायन में क्या परिवर्तन होता है ?

3

19. गुरुत्वानुवर्तन की परिभाषा लिखिए । किसी पादप के भागों में गुरुत्वानुवर्ती गतियों को दर्शाने के लिए नामांकित आरेख खींचिए ।

3

20. विकास की परिभाषा लिखिए । “विकास को प्रगति के समान नहीं माना जा सकता है ।” इस कथन की पुष्टि कीजिए ।

3

अथवा

“विकास की प्रक्रिया की अवधि में, अंग अथवा लक्षण नए कार्यों के लिए अनुकूलित हो सकते हैं ।” कोई उपयुक्त उदाहरण देकर इस तथ्य की व्याख्या कीजिए ।

3

21. किसी अवतल दर्पण का उपयोग किसी बिम्ब की विभिन्न स्थितियों में उसका प्रतिबिम्ब बनाने के लिए किया गया है । जब यह बिम्ब 15 cm फोकस दूरी के अवतल दर्पण के ध्रुव से 10 cm दूरी पर रखा है, तो इस स्थिति में निम्नलिखित के विषय में क्या निष्कर्ष निकाले जा सकते हैं ?

- (a) प्रतिबिम्ब की स्थिति  
(b) प्रतिबिम्ब का साइज़  
(c) प्रतिबिम्ब की प्रकृति

अपने निष्कर्षों की पुष्टि के लिए नामांकित किरण आरेख खींचिए ।

3





16. List three differentiating features between the processes of galvanisation and alloying. 3

Metals and Non-Metals

**OR**

Compare in tabular form the reactivities of the following metals with cold and hot water :

(a) Sodium

(b) Calcium

(c) Magnesium 3

17. Carbon, a member of group 14, forms a large number of carbon compounds estimated to be about three million. Why is this property not exhibited by other elements of this group? Explain. 3

Periodic Classification of Elements

18. A cheetah, on seeing a prey, moves towards him at a very high speed. What causes the movement of his muscles? How does the chemistry of cellular components of muscles change during this event? 3

Control and Coordination

19. Define geotropism. Draw a labelled diagram of a plant showing geotropic movements of its parts. 3

Control and Coordination

20. Define the term evolution. "Evolution cannot be equated with progress." Justify this statement. 3

**OR**

Heredity and Evolution

"During the course of evolution, organs or features may be adapted for new functions." Explain this fact by choosing an appropriate example. 3

21. A concave mirror is used for image formation for different positions of an object. What inferences can be drawn about the following when an object is placed at a distance of 10 cm from the pole of a concave mirror of focal length 15 cm?

(a) Position of the image

(b) Size of the image

(c) Nature of the image

Light: Reflection and Refraction

Draw a labelled ray diagram to justify your inferences. 3

22. माध्यम 'x' का माध्यम 'y' के सापेक्ष अपवर्तनांक  $2/3$  है तथा माध्यम 'y' का माध्यम 'z' के सापेक्ष अपवर्तनांक  $4/3$  है। माध्यम 'x' के सापेक्ष माध्यम 'z' का अपवर्तनांक ज्ञात कीजिए। यदि माध्यम 'x' में प्रकाश की चाल  $3 \times 10^8 \text{ ms}^{-1}$  है, तो माध्यम 'y' में प्रकाश की चाल परिकलित कीजिए।

3

23. कोई व्यक्ति निकट-दृष्टि दोष तथा दीर्घ-दृष्टि दोष दोनों से पीड़ित हो सकता है।

- इस स्थिति को क्या कहते हैं ?
- यह स्थिति कब उत्पन्न होती है ?
- इस दोष से पीड़ित व्यक्तियों को प्रायः जिस प्रकार के लेंसों की आवश्यकता होती है उसका नाम लिखिए। इस प्रकार के लेंसों का नामांकित आरेख खींचिए।

3

24. आप काँच के दो सर्वसम प्रिज़्मों का उपयोग किस प्रकार करेंगे जिससे कि पहले प्रिज़्म पर आपतित कोई पतला श्वेत प्रकाश पुंज दूसरे प्रिज़्म से श्वेत प्रकाश पुंज के रूप में ही निर्गत हो ? किरण आरेख खींचकर उसे नामांकित कीजिए।

3

### खण्ड ग

25. प्याज़ के रस में भिगोकर निकाली गई कपड़े की किसी पट्टी का उपयोग किसी द्रव 'X' के परीक्षण के लिए किया गया। द्रव 'X' ने उसकी गंध को परिवर्तित कर दिया। प्याज़ का रस किस प्रकार का सूचक है ? यही द्रव 'X' नीले लिटमस को लाल कर देता है। निम्नलिखित के साथ द्रव 'X' की अभिक्रिया के प्रेक्षणों को दर्शाने के लिए सूची बनाइए :

- ज़िंक की कणिकाएँ
- ठोस सोडियम कार्बोनेट

होने वाली अभिक्रियाओं के रासायनिक समीकरण लिखिए।

5

### अथवा

क्रिस्टलन जल की परिभाषा लिखिए। उदाहरणों के रूप में दो यौगिकों के रासायनिक सूत्र लिखिए। यह किस प्रकार सत्यापित किया जा सकता है कि क्रिस्टलन जल यौगिकों की अवस्था और रंग में अन्तर कर सकता है ?

5



22. The refractive index of a medium 'x' with respect to a medium 'y' is  $\frac{2}{3}$  and the refractive index of medium 'y' with respect to medium 'z' is  $\frac{4}{3}$ . Find the refractive index of medium 'z' with respect to medium 'x'. If the speed of light in medium 'x' is  $3 \times 10^8 \text{ ms}^{-1}$ , calculate the speed of light in medium 'y'.

Light: Reflection and Refraction

3

23. A person may suffer from both myopia and hypermetropia defects.

- (a) What is this condition called ?
- (b) When does it happen ?
- (c) Name the type of lens often required by the persons suffering from this defect. Draw labelled diagram of such lenses.

Human Eyes and Colorful World

3

24. How will you use two identical glass prisms so that a narrow beam of white light incident on one prism emerges out of the second prism as white light ? Draw and label the ray diagram.

Human Eyes and Colorful World

3

### SECTION C

25. A cloth strip dipped in onion juice is used for testing a liquid 'X'. The liquid 'X' changes its odour. Which type of an indicator is onion juice ? The liquid 'X' turns blue litmus red. List the observations the liquid 'X' will show on reacting with the following :

Chemical Reactions and Equation

- (a) Zinc granules
- (b) Solid sodium carbonate

Write the chemical equations for the reactions involved.

5

OR

Define water of crystallisation. Give the chemical formula for two compounds as examples. How can it be proved that the water of crystallisation makes a difference in the state and colour of the compounds ?

Chemical Reactions and Equation

5

26. (a) (i) सोने (गोल्ड) के वह दो गुण लिखिए जो इसे आभूषणों के लिए सबसे अधिक उपयुक्त बनाते हैं ।
- (ii) उन दो धातुओं के नाम लिखिए जो ऊष्मा के सबसे अच्छे चालक हैं ?
- (iii) उन दो धातुओं के नाम लिखिए जो हथेली पर रखने पर पिघल जाती हैं ।
- (b) इलेक्ट्रॉन-बिन्दु संरचना सहित आयनी यौगिक CaO के बनने की व्याख्या कीजिए । कैल्सियम और ऑक्सीजन के परमाणु क्रमांक क्रमशः 20 और 8 हैं । 5

27. (a) मानव शरीर के लिए पोषण क्यों आवश्यक है ?
- (b) आहार नाल के भीतर भोजन को कौन गति प्रदान करता है ?
- (c) मांसाहारियों की तुलना में शाकाहारियों की क्षुद्रांत्र अधिक लम्बी क्यों होती है ?
- (d) यदि जठर ग्रंथियाँ श्लेष्मा का स्रवण न करें, तो क्या होगा ? 5

28. किसी पुष्प में निषेचन को दर्शाने का स्वच्छ आरेख खींचिए और उस पर (a) परागनली, (b) नर जनन-कोशिका और (c) मादा जनन-कोशिका को नामांकित कीजिए । पुष्प में निषेचन की प्रक्रिया की व्याख्या कीजिए । निषेचन के पश्चात् (i) अण्डाशय और (ii) बीजाण्ड का क्या होता है ? 5

### अथवा

- (a) यौवनारम्भ किसे कहते हैं ?
- (b) मानव नर जनन तंत्र में नीचे दिए गए भागों के कार्यों का संक्षेप में वर्णन कीजिए :
- (i) वृषण
- (ii) शुक्राशय
- (iii) शुक्रवाहिका
- (iv) मूत्रमार्ग
- (c) वृषण उदर गुहा के बाहर स्थित क्यों होते हैं ?
- (d) उल्लेख कीजिए कि शुक्राणु मादा जनन-कोशिका की ओर किस प्रकार गति करते हैं । 5





26. (a) (i) Write two properties of gold which make it the most suitable metal for ornaments. **Metals and Non-Metals**
- (ii) Name two metals which are the best conductors of heat.
- (iii) Name two metals which melt when you keep them on your palm.

- (b) Explain the formation of ionic compound CaO with electron-dot structure. Atomic numbers of calcium and oxygen are 20 and 8 respectively. **Metals and Non-Metals**

5

27. (a) Why is nutrition necessary for the human body ? **Life Processes**
- (b) What causes movement of food inside the alimentary canal ?
- (c) Why is small intestine in herbivores longer than in carnivores ?
- (d) What will happen if mucus is not secreted by the gastric glands ?

5

28. Draw a neat diagram showing fertilisation in a flower and label (a) Pollen tube, (b) Male germ cell and (c) Female germ cell, on it. Explain the process of fertilisation in a flower. What happens to the (i) ovary and (ii) ovule after fertilisation ?

5

**OR****How do we Reproduce**

- (a) What is puberty ?
- (b) Describe in brief the functions of the following parts in the human male reproductive system :

**How do we Reproduce**

- (i) Testes
- (ii) Seminal vesicle
- (iii) Vas deferens
- (iv) Urethra
- (c) Why are testes located outside the abdominal cavity ?
- (d) State how sperms move towards the female germ cell.

5

29. किसी ऐसे परिपथ का व्यवस्था आरेख खींचिए जिसमें 2 V के तीन सेलों की बैटरी, पार्श्व में संयोजित  $10 \Omega$ ,  $20 \Omega$  तथा  $30 \Omega$  के तीन प्रतिरोधकों का संयोजन, एक प्लग कुंजी तथा एक ऐमीटर, सभी श्रेणी में संयोजित हैं। इस परिपथ का उपयोग करके निम्नलिखित का मान ज्ञात कीजिए :

- (a) प्रत्येक प्रतिरोधक से प्रवाहित धारा
- (b) परिपथ में प्रवाहित कुल धारा
- (c) परिपथ का कुल प्रभावी प्रतिरोध

5

अथवा

किसी 6 V की बैटरी से दो सर्वसम प्रतिरोधक, जिनमें प्रत्येक का प्रतिरोध  $15 \Omega$  है, बारी-बारी से पहले (i) श्रेणी में, और फिर (ii) पार्श्व में संयोजित किए गए हैं। प्रत्येक प्रकरण में प्रतिरोधकों के संयोजन द्वारा उपभुक्त शक्ति के अनुपात का परिकलन कीजिए।

5

30. (a) फ्लेमिंग का वाम-हस्त नियम लिखिए।
- (b) हम अपने घरों में जिस विद्युत् धारा का उपयोग करते हैं उसके तीन विशिष्ट लक्षणों की सूची बनाइए।
- (c) फ्यूज क्या होता है ? इसे सुरक्षा युक्ति क्यों कहते हैं ?
- (d) धातु के आवरण वाले विद्युत् साधित्रों को भूसम्पर्कित करना क्यों आवश्यक है ?

5



**29.** Draw a schematic diagram of a circuit consisting of a battery of 3 cells of 2 V each, a combination of three resistors of 10  $\Omega$ , 20  $\Omega$  and 30  $\Omega$  connected in parallel, a plug key and an ammeter, all connected in series. Use this circuit to find the value of the following :

Electricity

- (a) Current through each resistor
- (b) Total current in the circuit
- (c) Total effective resistance of the circuit

5

**OR**

Two identical resistors, each of resistance 15  $\Omega$ , are connected in (i) series, and (ii) parallel, in turn to a battery of 6 V. Calculate the ratio of the power consumed in the combination of resistors in each case.

5

Electricity

- 30.**
- (a) State Fleming's Left-hand rule. Magnetic Effect of Current
  - (b) List three characteristic features of the electric current used in our homes. Magnetic Effect of Current
  - (c) What is a fuse ? Why is it called a safety device ? Magnetic Effect of Current
  - (d) Why is it necessary to earth metallic electric appliances ?

5

Magnetic Effect of Current



## SECTION-A

1. Write the number of valence electrons present in a nitrogen atom  $\left( \begin{matrix} 14 \\ 7 \end{matrix} \text{N} \right)$ . [1]

**Answer:** Five

2. Define the term induced electric current. [1]

**Answer:** The electric current induced in a conductor due to the change in magnetic field is known as induced current.

3. Answer question number 3(a) – 3(d) on the basis of your understanding of the following paragraph and the related studied concepts.

Around the year 1800, only 30 elements were known. Dobereiner in 1817 and Newlands in 1866 tried to arrange the then known elements and framed laws which were rejected by the scientists. Even after the rejection of the proposed laws, many scientists continued to search for a pattern that correlated the properties of elements with their atomic masses.

The main credit for classifying elements goes to Mendeleev for his most important contribution to the early development of a Periodic table of element wherein the arranged the elements on the basis of their fundamental property, the atomic mass and also on the similarity of chemical properties. The formulae of their



hydrides and oxides were treated as basic criteria for the classification of the elements.

However, Mendeleev's classification also had some limitations as it could not assign the position to isotopes. He also left some gaps in the periodic table.

**3(a) State Mendeleev's Periodic Law. [1]**

**3(b) Why did Mendeleev leave some gaps in the Periodic table? [1]**

**3(c) If the letter 'R' was used to represent any of the elements in the group, then the hydride and oxide of carbon would respectively be represented as**

(i)  $RH_4, RO$

(ii)  $RH_4, RO_2$

(iii)  $RH_2, RO_2$

(iv)  $RH_2, RO$

[1]

**3 (d) Isotopes are**

(i) Atoms of an element with similar chemical properties but different atomic masses.

(ii) Atoms of different elements with similar chemical properties but different atomic masses.

(iii) Atoms of an element with different chemical properties but same atomic masses.





**(iv) Atoms of different elements with different chemical properties but same atomic masses.**

**[1]**

**Answer:**

- (a) According to the Mendeleev's periodic law, the physical and chemical properties of elements are periodic function of their atomic masses.
- (b) Mendeleev predicted the existence and the properties of some elements, which were not known at that time. Therefore, he left some gaps in the Periodic table.
- (c) (ii)
- (d) (i)

**4. Answer question numbers 4 (a) - 4 (d) on the basis of your understanding of the following paragraph and the related studies concepts-**

**India today is facing the problem of overuse of resources, contamination of water and soil and lack of methods of processing the waste. The time has come for the world to say goodbye to "single-use plastics". Steps must be undertaken to develop environment- friendly substitutes, effective plastic waste collection and methods of its disposal.**

**Indore treated 15 lakh metric tonnes of waste in just 3 years, through biomining and bioremediation techniques. Bioremediation**



**involves introducing microbes into a landfill to naturally 'break' it down and biomining involves using trammel machines to sift through the waste to separate the 'soil' and the waste component. The city managed to chip away 15 lakh metric tonnes of waste at a cost of around Rs 10 crore. A similar experiment was successfully carried out in Ahmedabad also.**

**4(a) State two methods of effective plastic waste collection in your school. [1]**

**4(b) Name any two uses of "single use plastic" in daily life. [1]**

**4(c) If we discontinue the use of plastic, how can an environment-friendly substitute be provided? [1]**

**4(d) Do you think microbes will work similarly in landfill sites as they work in the laboratory? Justify your answer. [1]**

**Answer:** (a) Two methods of effective plastic waste collection in the school are-

- i. Curbside Recycling
- ii. Drop-Off Recycling

(b) Two uses of "single use plastic" in daily life are-

- i. Plastic grocery bags
- ii. Plastic drinking bottles



(c) If we discontinue the use of plastic, we can use long-lasting environment-friendly substitutes like stainless steel or glass water bottles, reusable shopping bags, eco-friendly cutlery etc.

(d) Yes, microbes can work in landfill sites as they work in laboratory. The landfills can be broken down naturally by the process of bioremediation that involves the microbes.

**5. Which of the following statement is correct about the human circulatory system?**

- (A) Blood transports only oxygen and not carbon dioxide.**
- (B) Human heart has five chambers.**
- (C) Valves ensure that the blood does not flow backwards.**
- (D) Both oxygen-rich and oxygen-deficient blood gets mixed in the heart.**

**[1]**

**Answer: (C)**

Explanation: Blood can flow from the atria down into the ventricles. Valves open in one direction like trapdoors to let the blood pass through. Then they close, so the blood cannot flow backwards into the atria.

**6. Anaerobic process**

- (A) takes place in yeast during fermentation.**
- (B) takes place in the presence of oxygen.**
- (C) produces only energy in the muscles of human beings.**



**(D) Produces ethanol, oxygen and energy.**

**[1]**

**Answer: (A)**

Explanation: In yeast, anaerobic fermentation takes place in the presence of sugar but absence of oxygen. Anaerobic fermentation in yeast results in the production of ethanol and carbon dioxide.

**OR**

**Most of the digestion and absorption of the food takes place in the**

- (A) small intestine.**
- (B) liver.**
- (C) stomach.**
- (D) large intestine.**

**[1]**

**Answer: (A)**

Explanation: The small intestine is the part of digestive system where much of the digestion and absorption of food takes place. The primary function of the small intestine is to absorb nutrients and minerals present in the food.

**7. Fertilisation is the process of**

- (A) transfer of male gamete to female gamete.**
- (B) fusion of nuclei of male and female gamete.**
- (C) adhesion of male and female reproductive organs.**
- (D) the formation of gametes by a reproductive organ.**



[1]

**Answer: (B)**

Explanation: Fertilisation is the process of fusion of haploid gametes, (male and female) to form the diploid zygote.

8. If a person has five resistors each of value  $\frac{1}{5} \Omega$ , then the maximum resistance he can obtain by connecting them is [1]

- (A)  $1 \Omega$   
(B)  $5 \Omega$   
(C)  $10 \Omega$   
(D)  $25 \Omega$

**Answer: (A)**

Series combination of resistors gives maximum resistance

$$R_{\text{equivalent}} = R_1 + R_2 + R_3 + R_4 + R_5$$

$$R_{\text{equivalent}} = \frac{1}{5 \Omega} + \frac{1}{5 \Omega} + \frac{1}{5 \Omega} + \frac{1}{5 \Omega} + \frac{1}{5 \Omega} = 1 \Omega$$

**OR**

The resistance of a resistor is reduced to half of its initial value. In doing so, if other parameters of the circuit remain unchanged, the heating effects in the resistor will become

[1]

- (A) two times.





- (B) half.**
- (C) one-fourth.**
- (D) four times.**

**Answer: (B)**

Joule's law of heating is given by  $H = I^2RT$

If other parameters remain constant, the amount of heat produced,  $H$  is directly proportional to  $R$ .

**9. Fleming Right-hand rule gives [1]**

- (A) magnitude of the induced current.**
- (B) magnitude of the magnetic field.**
- (C) direction of the induced current.**
- (D) both, direction and magnitude of the induced current.**

**Answer: (C)**

Fleming's right-hand rule states that if we stretched our right hand's thumb, index finger and middle finger in such a way so that all three are mutually perpendicular, thumb shows the direction of motion of conductor with respect to magnetic field, index finger shows the direction of magnetic field than middle finger shows the direction of induced current in the conductor.

**10. Which one of the following statements is not true about nuclear energy generation in a nuclear reactor? [1]**

- (A) Energy is obtained by a process called nuclear fission.**



- (B) The nucleus of Uranium is bombarded with high energy neutrons.**
- (C) A chain reaction is set in the process.**
- (D) In this process a tremendous amount of energy is released at a controlled rate.**

**Answer: (B)**

Slow moving neutrons are bombarded on the nucleus of Uranium to break the nucleus in smaller stable nuclei.

**OR**

**The biggest source of energy on Earth's surface is [1]**

- (A) Biomass**
- (B) Solar radiations**
- (C) Tides**
- (D) Winds**

**Answer: (B)**

Maximum energy present on the earth is converted form of solar energy.

**11. Food web is constituted by [1]**

- (A) relationship between the organism and the environment.**
- (B) relationship between plants and animals.**
- (C) various interlinked food chains in an ecosystem.**



**(D) relationship between animals and environment.**

**Answer: (C)**

In a food web, many food chains are linked together. Thus, it is a network of interlinked food chains in an ecosystem. In this network, every organism is eaten by more than one organism, who are again eaten by other different organisms. Unlike a food chain, the food web is represented by the crisscross pattern of lines.

**12. Choose the incorrect statement from the following:**

**[1]**

**(A) Ozone is a molecule formed by three atoms of oxygen.**

**(B) Ozone shields the surface of the Earth from ultraviolet radiations.**

**(C) Ozone is deadly poisonous.**

**(D) Ozone gets decomposed by UV radiations.**

**Answer: (D)**

Ozone ( $O_3$ ) is an inorganic molecule made up of three oxygen atoms. It is not decomposed by UV (ultraviolet) radiations, rather these radiations help in the formation of ozone.

The chemical reaction involved in ozone formation is as follows:

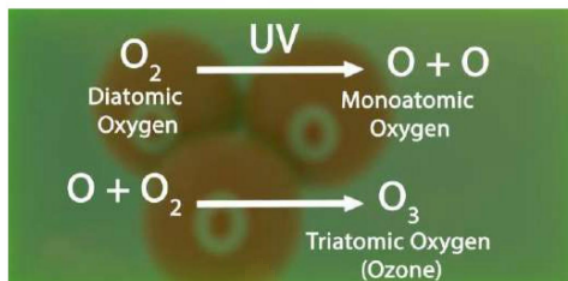

**13. For question numbers 13 and 14, two statements are given- one labelled as Assertion (A) and the other labelled as Reason (R). Select the correct answer to these questions from the codes (a), (b), (c) and (d) as given below:**

- (a) Both (A) and (R) are true and (R) is the correct explanation of the assertion (A).
- (b) Both (A) and (R) are true, but (R) is not the correct explanation of the assertion (A).
- (c) (A) is true, but (R) is false.
- (d) (A) is false, but (R) is true.

**Assertion (A):** Following is a balanced chemical equation for the action of steam on iron:



**Reason (R):** The law of conservation of mass holds good for a chemical equation.

[1]

**Answer: (a)**

**14. Assertion (A):** The sex of a child in human beings will be determined by the type of chromosome he/she inherits from the father.



**Reason (R): A child who inherits 'X' chromosome from his father would be a girl (XX), while a child who inherits a 'Y' chromosome from the father would be a boy (XY). [1]**

**Answer:** (a) Both (A) and (R) are true and ® is the correct explanation of the assertion (A).

All human beings have 23 pairs of chromosomes in the nuclei of their cells. Out of these two are the sex chromosomes named as X and Y.

A female has two X chromosomes while male has one X and one Y chromosome.

If the sperm containing X chromosome fertilize the egg. The zygote will contain two X sex chromosomes. This zygote will develop into a female child.

If the sperm has Y chromosome and it fertilizes the egg the zygote. The zygote will develop into the male child.

Hence, the type of sperm contributed by father determines the sex of the unborn baby.

### SECTION-B

**15. Lead nitrate solution is added to a test tube containing potassium iodide solution.**

**(a) Write the name and colour of the compound precipitated.**





**(b) Write the balanced chemical equation for the reaction involved.**

**(c) Name the type of this reaction justifying your answer.**

**[3]**

**Answer:**

(a) Name of compound precipitated: Lead iodide

Colour of the compound precipitated: Yellow

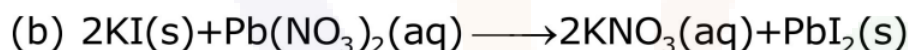

(c) This is a double displacement reaction because in the reaction two compounds exchange their ions to form two new compounds. Here both lead nitrate and potassium iodide are exchanging their ions.

**OR**

**What happens when food materials containing fats and oils are left for a long time/ List two observable changes and suggest three ways by which this phenomenon can be prevented. [3]**

**Answer:** When food materials containing fats and oils are left for a long time they undergo oxidation and their **taste** and **smell change**.

This can be prevented by-

1. Using airtight and light protecting packing
2. Using antioxidants like vitamin A and C
3. Filling nitrogen gas in chips container



**16. List three differentiating features between the processes of galvanisation and alloying. [3]**

**Answer:**

<b>Galvanisation</b>	<b>Alloying</b>
Galvanisation is the process of depositing a thin layer of zinc metal on iron objects to protect them from rusting.	A homogeneous mixture of two or more metals or a metal and a non-metal to change the properties of pure state metals and protect them from rust.
It can be done by spraying molten zinc on the iron surface and dipping iron objects into molten zinc.	It can be done by alloying iron object with the chromium and nickel.
It does not affect the properties of iron (metal).	It changes the hardness, tensile strength and electrical resistance of a metal.

**OR**

**Compare in tabular form the reactivities of the following metals with cold and hot water:**

**(a) Sodium**

**(b) Calcium**

**(c) Magnesium**

**[3]**

**Answer:**

<b>Metal</b>	<b>Reactivity</b>	<b>Reactions</b>
Sodium (Na)	It reacts vigorously	$2\text{Na(s)} + 2\text{H}_2\text{O(l)} \longrightarrow 2\text{NaOH(aq)} + \text{H}_2\text{(g)}$



	with cold water.	
Calcium (Ca)	It reacts slowly with cold water and moderately with hot water.	$\text{Ca(s)} + 2\text{H}_2\text{O(l)} \longrightarrow \text{Ca(OH)}_2 + \text{H}_2\text{(g)}$ <p>(Hot)</p>
Magnesium (Mg)	Magnesium does not react with cold water. It reacts slowly with hot water and vigorously with steam.	$\text{Mg(s)} + 2\text{H}_2\text{O(l)} \longrightarrow \text{Mg(OH)}_2 + \text{H}_2\text{(g)}$ <p>(Hot)</p> $\text{Mg(s)} + \text{H}_2\text{O(l)} \longrightarrow \text{MgO} + \text{H}_2\text{(g)}$ <p>(Steam)</p>

**17. Carbon, a member of group 14, forms a large number of carbon compounds estimated to be about three million. Why is this property not exhibited by other elements of this group? Explain. [3]**

**Answer:**

1. **Tetravalency:** Carbon can easily form four covalent bonds to other atoms.
2. **Catenation:** Carbon can easily form covalent bonds to other carbon atoms and the carbon-carbon bonds are more stable than the other



element to same element bonds formed by other member of group 14.

- 3. Formation of multiple bonds:** Carbon can form not only a single bond but also it can form double or single bonds with same or different elements.

Since these properties are not exhibited by other elements of this group, therefore, the number of carbon compounds is very large as compared to the other elements of group 14.

- 18. A cheetah, on seeing a prey, moves towards him at a very high speed. What causes the movement of his muscles? How does the chemistry of cellular components of muscles change during this event? [3]**

**Answer:** A cheetah possesses an extremely flexible spine which allows for extreme flexion and extension while moving towards a prey at a very high speed.

Rapid respiration is required for a high-intensity output of the chasing activity. Thus, a cheetah consequently respire anaerobically. During anaerobic respiration, partial breakdown of glucose takes place, which leads to the accumulation of lactic acid in the muscles as the end-product.

- 19. Define geotropism. Draw a labelled diagram of a plant showing geotropic movement of its parts. [3]**

**Answer:** Geotropism: Geotropism refers to the growth of the parts of a plant in response to gravity.

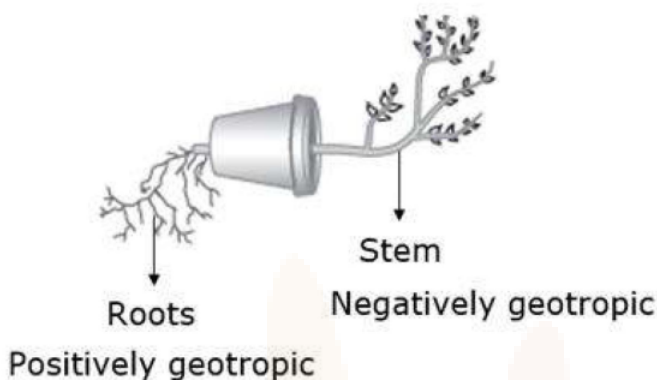

Figure: A plant showing geotropic movement

**20. Define the term evolution. "Evolution cannot be equated with progress." Justify this statement.**

**[3]**

**Answer:** Evolution is the gradual and continuous changes in the traits of an individual that accumulates and enables it to survive better in its surroundings.

Evolution cannot be equated with progress from lower organisms to higher organisms. Evolution leads to the production of diversity and the shaping this diversity by environmental selection. In addition, even the simpler life forms continue to flourish as we can see in case of bacteria. These are one of the simplest life form that inhabit in extreme cold or hot conditions.

**OR**

**"During the course of evolution, organs or features may be adapted for new functions."**





**Explain this fact by choosing an appropriate example. [3]**

**Answer:** The organs or features adapted for new functions during evolution are:

- (i) Some dinosaur had feathers for insulation in cold weather but in case of birds they were used for flying.
- (ii) Older life forms, such as bacteria were able to survive in most of the inhospitable habitats like, hot springs, deep-sea, thermal vents and the ice in Antarctica.

**21. A concave mirror is use for image formation for different positions of an object. What inferences can be drawn about the following when an object is placed at a distance of 10 cm from the pole of a concave mirror of focal length 15 cm?**

**(A) Position of the image**

**(B) Size of the image**

**(C) Nature of the image**

**Draw a labelled ray diagram to justify your inferences. [3]**

**Answer:** Given,

Position of object,  $u = -10$  cm

Focal length of concave mirror,  $f = -15$  cm

(a) Using mirror formula,

$$\frac{1}{v} = \frac{1}{f} - \frac{1}{u}$$
$$\Rightarrow \frac{1}{v} = \frac{1}{-15 \text{ cm}} - \frac{1}{(-10 \text{ cm})} = \frac{1}{30 \text{ cm}}$$
$$\Rightarrow v = 30 \text{ cm}$$

So, the position of image is 30 cm behind the mirror.

(b) Using magnification formula,  $m = \frac{h_i}{h_o} = -\frac{v}{u}$

$$\Rightarrow \frac{h_i}{h_o} = -\frac{30 \text{ cm}}{(-10 \text{ cm})} = 3 \text{ cm}$$
$$\Rightarrow h_i = 3h_o$$

So, the size of the image is three times that of the size of the object.

Here the object is placed in between focus and pole of the concave mirror, so the image formed will be virtual and magnified.

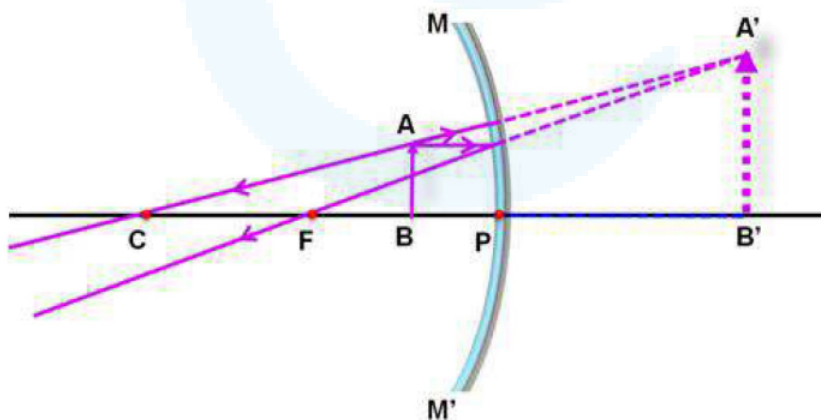



**22. The refractive index of a medium 'x' with respect to a medium 'y' is  $\frac{2}{3}$  and the refractive index of medium 'y' with respect to medium 'z' is  $\frac{4}{3}$ . Find the refractive index of medium 'z' with respect to medium 'x'. If the speed of light in medium 'x' is  $3 \times 10^8 \text{ ms}^{-1}$ , calculate the speed of light in medium 'y' [3]**

**Answer:**

Given :

Refractive index of medium 'x'

with respect to medium 'y',  $\mu_{xy} = \frac{2}{3}$

Refractive index of medium 'y'

with respect to medium 'z',  $\mu_{yz} = \frac{4}{3}$

Refractive index of medium 'z'

with respect to medium 'x',

$$\mu_{zx} = \frac{1}{\mu_{xy} \times \mu_{yz}} = \frac{1}{\frac{2}{3} \times \frac{4}{3}} = \frac{9}{8}$$

Refractive index of medium 'z'

with respect to medium 'x' is  $\frac{9}{8}$ .

Speed of light in medium 'y',

$$v = c \times \mu_{xy} = 3 \times 10^8 \text{ m/s} \times \frac{2}{3} = 2 \times 10^8 \text{ m/s}$$

**23. A person may suffer from both myopia and hypermetropia defects.**

**(a) What is this condition called?**

**(b) When does it happen?**

**(c) Name the type of lens often required by the suffering from this defect. Draw labelled diagram of such lenses. [3]**

**Answer:**

- (a) This condition is called presbyopia.
- (b) It happens in old age.
- (c) Bifocal lens is required for clear vision by the person suffering from presbyopia.

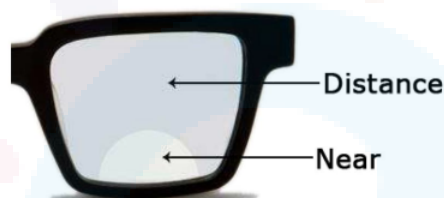

**24. How will you use two identical glass prisms so that a narrow beam of white light incident on one prism emerges out of the second prism as white light? Draw and label the ray diagram. [3]**

**Answer:** One glass prism must be placed in inverted position with respect to other, when white light passes through first prism, dispersion happens and white light splits into seven colour. When these colour light falls on the inverted prism, then light of seven colours combine to give white light.

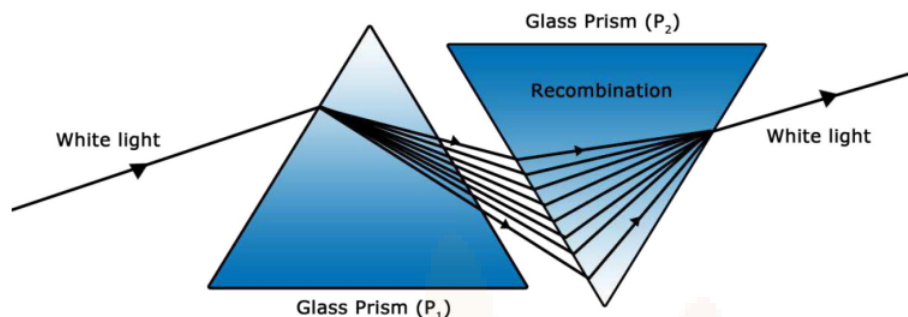

### SECTION-C

25. A cloth strip dipped in onion juice is used for testing a liquid 'X'. The liquid 'X' changes its odour. Which type of an indicator is onion juice? 'The liquid 'X' turns blue litmus red. List the observations the liquid 'X' will show on reacting with the following:

(a) Zinc granules

(b) Solid sodium carbonate

Write the chemical equations for the reactions involved. [5]

**Answer:** Onion juice is an olfactory indicator. Since the liquid 'X' turns blue litmus red, therefore, it is an acid.

(a) When liquid 'X' (an acid like HCl) reacts with zinc granules, bubbles of hydrogen will be formed.







(b) When liquid 'X' (an acid like HCl) reacts with sodium carbonate, carbon dioxide gas will be liberated.

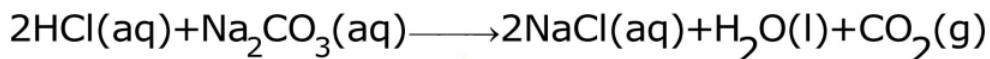

**OR**

**Define water of crystallization. Give the chemical formula for two compounds as examples. How can it be proved that the water of crystallization makes a difference in the state and colour of the compounds? [5]**

**Answer:** Water of crystallisation is the number of molecules of water which are loosely bonded to one molecule of salt.

For example:

- (1)  $\text{BaCl}_2 \cdot 2\text{H}_2\text{O}$
- (2)  $\text{CuSO}_4 \cdot 5\text{H}_2\text{O}$

We can prove that by heating the compound containing water of crystallisation, its colour or state change due to the removal of water of crystallisation.

For example

- (1) Copper sulphate crystals containing water of crystallisation are blue but on heating they turn white.
- (2) Similarly plaster of Paris is a white powder and on mixing with water it changes to gypsum which forms a hard solid mass.



- 26. (a) (i) Write two properties of gold which make it the most suitable metal for ornaments.**
- (ii) Name two metals which are the best conductors of heat.**
- (iii) Name two metals which melt when you keep them on your palm.**
- (b) Explain the formation of ionic compound CaO with electron-dot structure. Atomic numbers of calcium and oxygen are 20 and 8 respectively.**

**[5]**

**Answer:** (a)(i) Gold is inert metal and it has shiny surface. It is also malleable and ductile. Therefore, it is used for making ornaments.

(ii) Copper and aluminium

(iii) Cesium and gallium

(b) The atomic number of calcium and oxygen is 20 and 8 respectively.

The electronic configuration of calcium will be 2, 8, 8, 2 thus, it has 2 electrons in its outermost shell. On the other hand, oxygen (2, 6) has 6 electrons in its outermost shell. By losing two electrons, calcium atom forms a calcium ion ( $\text{Ca}^{2+}$ ) while by gaining 2 electrons; oxygen atom forms an oxide ion ( $\text{O}^{2-}$ ). Calcium reacts with oxygen to form an ionic compound calcium oxide (CaO).



The electron dot representation for the formation of calcium oxide is given below.

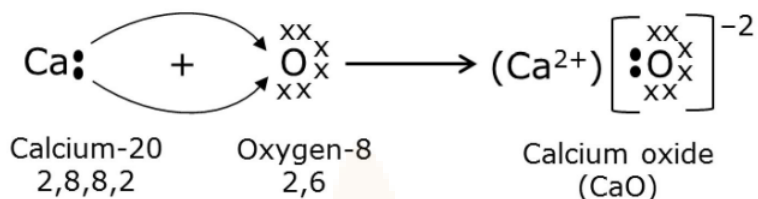

- 27. (a) Why is nutrition necessary for the human body?**
- (b) What causes movement of food inside the alimentary canal?**
- (c) Why is small intestine in herbivores longer than in carnivores?**
- (d) What will happen if mucus is not secreted by the gastric glands?**

**[5]**

**Answer:** (a) We obtain nutrition from the food we eat. This nutrition provides us energy for survival, growth and reproduction.

(b) Peristalsis mainly causes the movement of food inside the alimentary canal.

It is defined as a series of wave-like muscular contractions that propels the food inside an alimentary canal.

(c) The small intestine in herbivores is longer than in carnivores because herbivores are plant-eating animals. Plants are made up of cellulose and fibres which are not easily digested.



Therefore, for complete digestion of food, they require a longer digestive tract.

Also, many small bacteria are present in the intestine of herbivores that help in the breakdown of cellulose into glucose. This glucose is used by them as an energy source.

- (d) The gastric glands present in the stomach secrete hydrochloric acid, an enzyme – pepsin, and mucus. Hydrochloric acid provides an acidic medium for the enzyme to function. Pepsin digests proteins into smaller peptides. The mucus provides protection to the inner lining of the stomach from the action of the acid.

If mucus is not secreted by the gastric glands, it may erode the inner lining of the stomach resulting in ulcer and acidity.

**28. Draw a neat diagram showing fertilisation in a flower and label (a) pollen tube, (b) male germ cell, (c) female germ cell. Explain the process of fertilisation in a flower. What happens to the (i) ovary and (ii) ovule after fertilisation? [5]**

**Answer:**

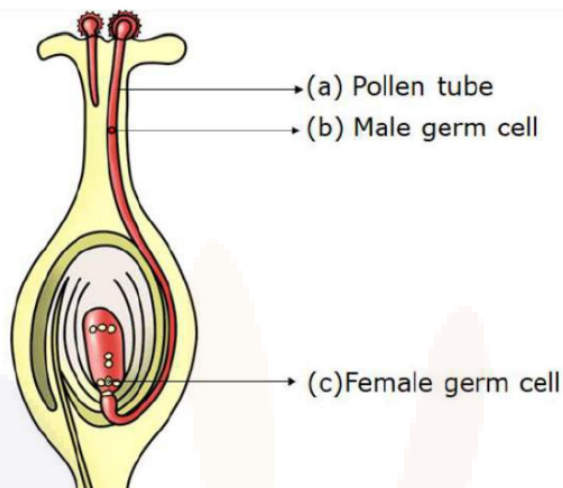

### Germination of Pollen on Stigma

When a mature pollen grain reaches the stigma of a flower, it absorbs the sugary secretions of the stigma, swells up and ruptures.

It divides and releases two male gametes, which move down the style to reach the ovary via pollen tube.

On entering the ovule of the ovary through a small opening, called micropyle, one of the male gamete fuses with the female gamete to form a zygote by the process of fertilisation. The other one fuses with the two polar nuclei by the process called triple fusion. Since the fertilisation has occurred twice, it is said that angiospermic plants undergo double fertilisation.

Post fertilisation,

- (i) Ovary develops into fruit
- (ii) Ovule develops into seed





**OR**

- (a) What is puberty?**
- (b) Describe in brief the functions of the following parts in the human male reproductive system:**
- (i) Testes**
  - (ii) Seminal vesicle**
  - (iii) Vas deferens**
  - (iv) Urethra**
- (c) Why are testes located outside the abdominal cavity?**
- (d) State how sperms move towards the female germ cell.**

**[5]**

**Answer:**

- (a) The age at which sex hormones begin to produce and reproductive organs of both male and female become functional is termed as puberty. At puberty, both male and female become sexually mature.
- (b) (i) Testes: Testes produce male sex cells called sperms and male sex hormone called testosterone.  
(ii) Seminal vesicle: Seminal vesicles store sperms and add seminal fluids to the sperms that make their transport easier. The seminal fluids also provide nutrition to the sperms.



- (iii) Vas deferens: Vas deferens manages the transportation of the mature sperms to the urethra.
- (iv) Urethra : Urethra is a common passage for both urine and sperm. At a time, either of these two fluids are released from the body.
- (c) A pair of testes is located outside the abdominal cavity in a pouch-like structure called scrotum to provide accurate temperature for the process of spermatogenesis. The process of spermatogenesis requires  $2-3^{\circ}\text{C}$  less than the body temperature.
- (d) Sperms have a long tail that helps them move towards the female germ-cell.

**29. Draw a schematic diagram of a circuit consisting of a battery of 3 cells of 2 V each, a combination of three resistors of  $10\ \Omega$ ,  $20\ \Omega$  and  $30\ \Omega$  connected in parallel, a plug key and an ammeter, all connected in series. Use this circuit to find the value of the following :**

**(a) Current through each resistor**

**(b) Total current in the circuit**

**(c) Total effective resistance of the circuit [5]**

**Answer:**

Circuit diagram :

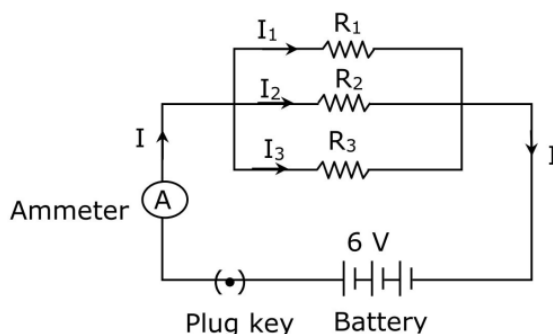



Given:

Voltage in the circuit =  $2\text{ V} + 2\text{ V} + 2\text{ V} = 6\text{ V}$

Resistance,  $R_1 = 10\ \Omega$ ,  $R_2 = 20\ \Omega$  and  $R_3 = 30\ \Omega$

Let  $I$  be the total current flowing in the circuit and  $R$  be the total effective resistance of the circuit.

According to Ohm's law,  $V = IR$

(a) Let electric current flowing through  $10\ \Omega$ ,  $20\ \Omega$  and  $30\ \Omega$  resistors be  $I_1$ ,  $I_2$  and  $I_3$  respectively.

According to Ohm's law,  $V = IR$

$$I_1 = \frac{6\text{ V}}{10\ \Omega} = 0.6\text{ A}$$

$$I_2 = \frac{6\text{ V}}{20\ \Omega} = 0.3\text{ A}$$

$$I_3 = \frac{6\text{ V}}{30\ \Omega} = 0.2\text{ A}$$

(b) Total current flowing in the circuit,

$$I = I_1 + I_2 + I_3$$

$$\therefore I = 0.6\text{ A} + 0.3\text{ A} + 0.2\text{ A} = 1.1\text{ A}$$

(c) Total effective resistance of the circuit,  $R = \frac{V}{I}$

$$\Rightarrow R = \frac{6\text{ V}}{1.1\text{ A}} = 5.45\ \Omega$$



**OR**

**Two identical resistors, each of resistance  $12 \Omega$ , are connected in (i) series, and (ii) parallel, in turn to a battery of  $6 \text{ V}$ . Calculate the ratio of the power consumed in the combination of resistors in each case. [5]**

**Answer:**

Given:

Voltage in the circuit =  $6 \text{ V}$

Resistance,  $R_1 = R_2 = 15 \Omega$

(i) When the two resistances connected in series:

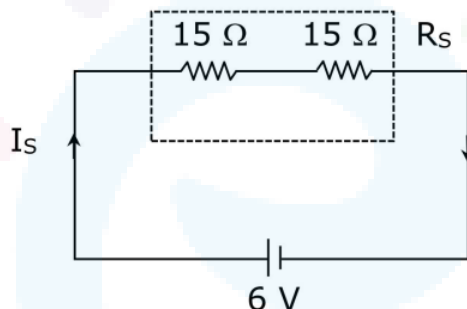

Effective resistance of the circuit,  $R_s = R_1 + R_2$

$$R_s = 15 \Omega + 15 \Omega = 30 \Omega$$

Power consumed by the circuit,  $P_s = \frac{V^2}{R_s}$

$$\Rightarrow P_s = \frac{(6 \text{ V})^2}{30 \Omega} = 1.2 \text{ W}$$

(ii) When the two resistances connected in parallel:

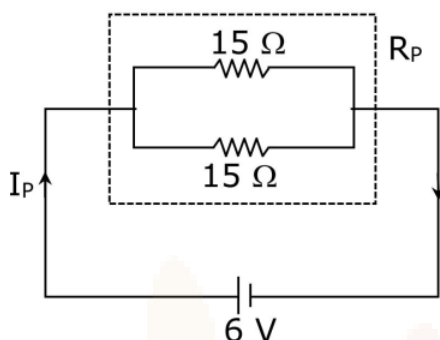

Effective resistance of the circuit,  $\frac{1}{R_p} = \frac{1}{R_1} + \frac{1}{R_2}$

$$\Rightarrow \frac{1}{R_p} = \frac{1}{15\ \Omega} + \frac{1}{15\ \Omega} = \frac{1}{30\ \Omega}$$

Power consumed by the circuit,  $P_p = \frac{V^2}{R_p}$

$$\Rightarrow P_p = \frac{(6\ \text{V})^2}{30\ \Omega} = 1.2\ \text{W}$$

$\therefore$  Ratio =  $P_s : P_p = 1.2\ \text{W} : 1.2\ \text{W} = 1 : 1$

So, the ratio of power consumption is 1:1.

**30. (a) State Fleming's Left-hand rule.**

**(b) List three characteristic features of the electric current used in our homes.**

**(c) What is a fuse ? Why is it called a safety device ?**

**(d) Why is it necessary to earth metallic electric appliances ?**

**[5]**

**Answer:**

(a) Fleming's left-hand rule states that if we stretch the thumb, the forefinger and the middle finger of our left hand in mutually perpendicular directions such that the forefinger gives the direction of current, middle finger points in the direction of magnetic field, then gives the direction of the force or motion of the conductor.

(b) The electric current supplied to our home is alternating in nature. It has following characteristics.

1. It is time varying current.
2. It has frequency of 50 Hz in India.
3. It can be transferred to long distances efficiently.

(c) Fuse is a safety device used in electrical circuit and appliances. It is called safety device because it prevents damage to the appliances and the electrical circuit due to overloading.

(d) The metallic electric appliances are earthed using earth wire as it provides a low resistance path to electric current thus ensuring that any leakage current to the metallic body of the appliance keeps its potential to that of the earth, and the user may not get a severe electric shock.